

DST800

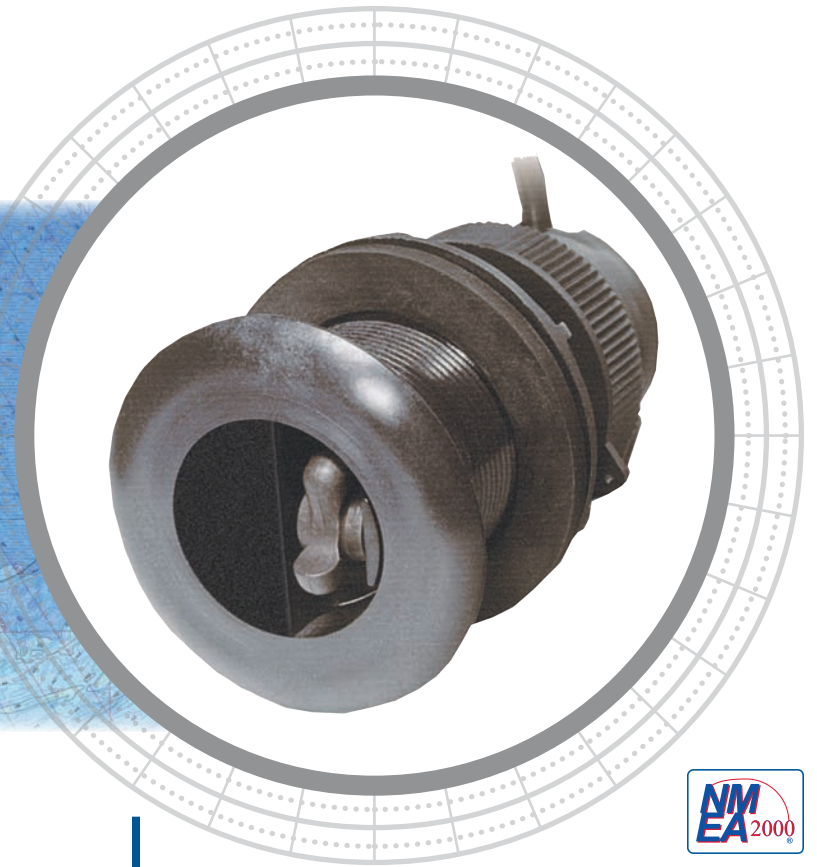
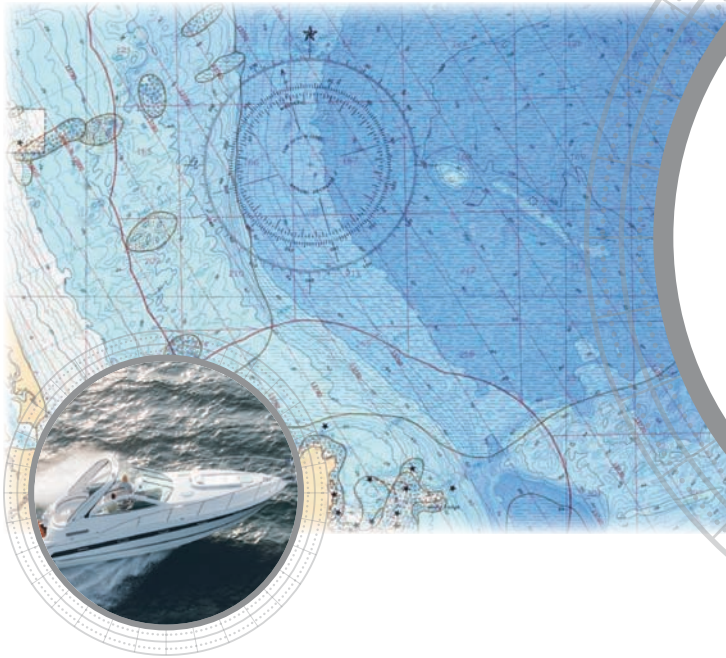

The Smart Alternative!

AirMar's DST800 Smart™ Sensor features embedded micro-electronics. Depth, speed, and temperature signals are processed inside the sensor and can be displayed on any radar, chart plotter, or device that accepts NMEA 0183 or NMEA 2000® data. The 235 kHz frequency prevents mutual interference with other echosounders on the vessel.

Single Choice for Depth, Speed, and Temperature!

The DST800 is the market's first Retractable TRIDUCER® Multisensor offering depth, speed, and temperature in a single, 51 mm (2") fitting. Only one hole through the hull simplifies the installation—an attractive feature for boat builders and boat owners alike.

Three-In-One

Patented, speed-signal-processing enhancements provide excellent paddlewheel accuracy below 5 knots (6 MPH) and smooth linear output at all vessel speeds. The transducer's wide, fan-shaped, fore-aft beam is able to find bottom even when installed on steep deadrise hulls or heeling sailboats. You also get true water-temperature readings with the DST800's reliable temperature sensor.

Valve Closes the Gap!

AirMar's innovative housing design incorporates the popular self-closing valve. When a transducer insert is removed, the valve minimizes water flow into the boat.

Smart™ Sensor

TRIDUCER® Multisensor
Thru-Hull Transducer

Features

- The all-in-one Smart Sensor
- Depth, speed, and temperature in one compact housing
- Available in NMEA 0183 and NMEA 2000® versions
- 235 kHz frequency prevents mutual interference with other echosounders on the vessel
- Plastic, bronze, or stainless steel housings available
- Fast-response temperature sensor provides $\pm 0.2^{\circ}\text{C}$ ($\pm 0.1^{\circ}\text{F}$) accuracy
- Available as a Smart Sensor at 235 kHz or an analog output sensor operating at either 200 kHz or 235 kHz
- Available in low-profile, countersunk, or beveled-edge housings



Sensing Technology

www.airmar.com

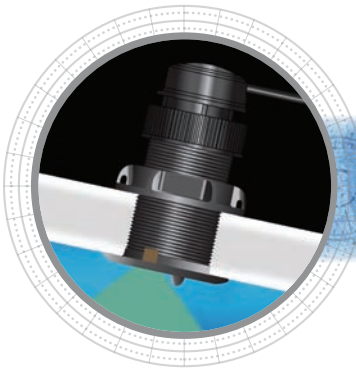

Technical Information

235 kHz-F NMEA 0183 / NMEA 2000®

Number of Elements and Configuration		
Beamwidth (@-3 dB)	10° x 44°	
RMS Power (W)	60 W	100 W

SPECIFICATIONS

Weight:
 —0.9 kg (2.0 lb)—Plastic
 —1.6 kg (3.5 lb)—Bronze
 —1.9 kg (4.2 lb)—Stainless Steel

Acoustic Window: Urethane

Hull Deadrise: Up to 22°

Data Update Rate: 1 per second

Minimum Depth Range: 0.5 m (1.6')

Maximum Depth Range:
 —Up to 70 m (30')—NMEA 0183
 —Up to 100 m (330')—NMEA 2000

Pressure Rating: 3 m (10')

Pulse Rate: 20,000 p/nm* (5.6 Hz per knot)—*p/nm = pulses per nautical mile

Supply Voltage:
 —10 VDC to 25 VDC—NMEA 0183
 —9 VDC to 16 VDC—NMEA 2000

Supply Current:
 —40 mA—NMEA 0183
 —200 mA—NMEA 2000

Standard Cable Length:
 —10 m (33')—NMEA 0183
 —6 m (20') devicenet—NMEA 2000

Temperature Sensor Accuracy: ±0.5°C (±1.8°F)

Temperature Sensor Range: -10°C to 40°C (14°F to 104°F)

NMEA 2000® Load Equivalency Number (LEN): 4

CE Regulation: Complies to IERC945

DATA OUTPUT PROTOCOL

NMEA 0183 Sentence Structure
 \$SDBT, DDPT... Depth
 \$VWVHW..... Speed
 \$VWLW..... Distance
 \$YXMTW..... Water Temperature

NMEA 2000® Supported PGNs
 59392..... ISO Acknowledgement
 600928..... ISO Address Claim
 126208..... Acknowledge Group Function
 126464..... Transmit PGN List Group Function
 126464..... Received PGN List Group Function
 126996..... Product Information
 128259..... Speed (Speed Water Reference)
 128267..... Water Depth (With Transducer Offset)
 128275..... Distance Log
 130310..... Environmental Parameters (Water Temperature)
 130311..... Environmental Parameters (Water Temperature)

DIMENSIONS

P617V Plastic, B617V Bronze, and SS617V Stainless Steel

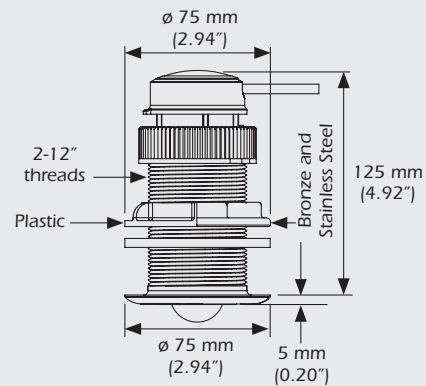

B17V Bronze

