

Congratulations, you have purchased a Facnor reefing system. Over 20 years Facnor has gained an excellent reputation in manufacturing furling systems that feature Innovation and Reliability. Sturdy and easy-to-use, your Facnor reefing system will give you satisfaction when either cruising or racing.

TABLE OF CONTENTS

1- Assembly drawing	p. 18
2- Package inventory	p. 18
2.1 – Box content	p. 19
2.2 – Tube content	p. 20
2.3 – Determining which section length should be used	p. 20
3- Pre-installation notes	p. 21/22
4- Assembly stages	p. 23
4.1 – Assembly of the halyard deflector	p. 23
4.2 – Assembly of the top cap and the top section	P. 23
4.3 – Fitting the halyard swivel	p. 24
4.4 – Assembling foil sections	p. 24
4.5 – Fitting the telescopic section	p. 24
4.6 – Fitting the feeder	p. 25
4.7 – Fitting the bearing into the telescopic section	p. 25
4.8 – Fixing the telescopic section in the drum	p. 25
4.9 – Fixing the bottom of the drum	p. 26
4.10 – Adjusting sections	p. 27
4.11 – Fixing the sail feeder	p. 27
5- Installation of the reefing line	p. 28
6- Adjusting the furling line guide	p. 28
7- Fitting the pre-feeder (LX/RX ranges)	p. 28
8- Specific installations	p. 29
9- Changing furling system into headfoil (LX/RX/RS removable drums)	p. 29
10- Post-installation check-list	p. 30
11- Furling tips.....	p.31

Before beginning assembly, we recommend that you read these instructions carefully so as to familiarize yourself with the parts, installation and the use of your Facnor furling and reefing system.

1- ASSEMBLY DRAWING

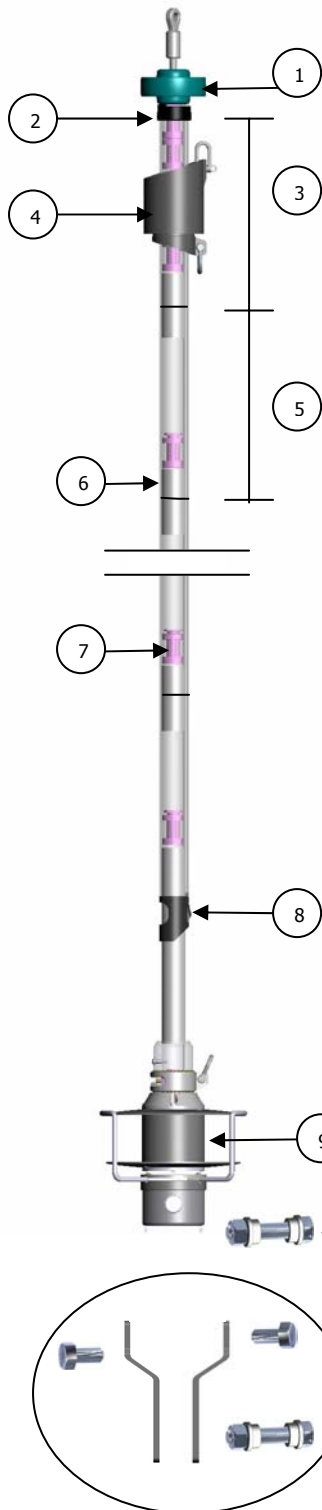

- 1 halyard deflector
- 2 top cap
- 3 top foil section
- 4 halyard swivel
- 5 2-meter-standard section
- 6 connector
- 7 black bearing (split into 2 half bearings)
- 8 sail feeder
- 9 drum

Lower drum fixing : 2 possible assemblies (see p.24)

- 10 pin with nylon bushes
- or**
- 11 turnbuckle kit (stainless steel curved plates, optional)

2- PACKAGE INVENTORY

The Facnor headsail reefing system comprises:



2.1 BOX CONTENT

2.1.1 Standard components

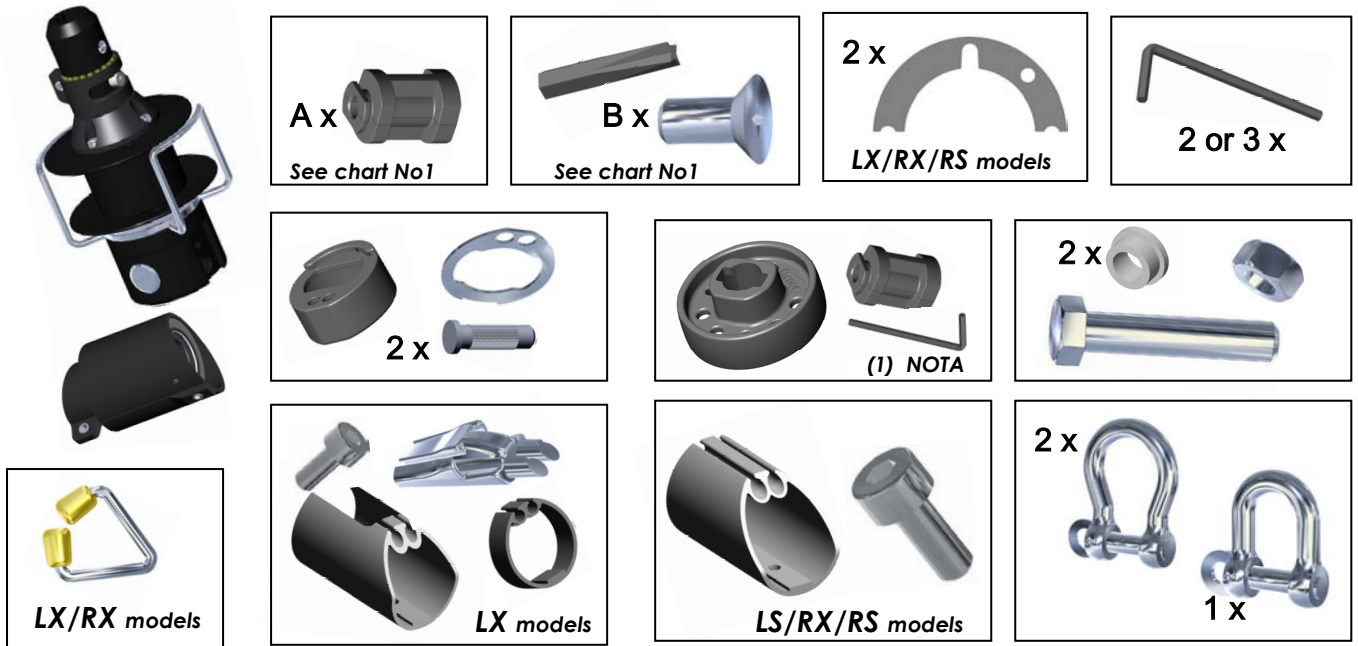

⁽¹⁾ **NOTE :** for LS/LX330 models, the halyard deflector wheel has been replaced by a block diverting the halyard and this is to be riveted onto the mast.

Chart No1

Maximum forestay length	8M30	10M40	12M40	14M40	16M40	18M40	20M40	22M40
A = Number of bearings necessary*	7	8	9	10	11	12	13	14
B = Number of screws necessary *	16	20	24	28	32	36	40	44

* **NOTE :** the quantity contained in the bag is superior to the number of screws or bearings required

2.1.2 Optional extras (not included in standard kit)

- Internal turnbuckle option



Drum fitted with internal turnbuckle option

- Turnbuckle kit (for installation see p. 24)



- Furling line kit (for installation see p. 26)

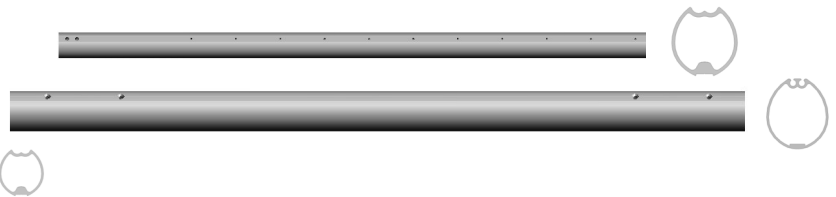



Chart No.2

Length-rope \varnothing	20M x \varnothing 06MM	24M x \varnothing 08MM	24M x \varnothing 10MM
Quantity C	2	2	3
Quantity D	2	2	2
Furl. system model	LS/LX 60-100 RX70-100	LS/LX 130-180 RX130-200	LS/LX 200-290 RX260-300

2.2 TUBE CONTENT

1. one telescopic section (1M40)
2. external twin-groove sections
3. connectors



 ** For OEM furling systems, delivered originally to the shipyard, the top section may be shorter than 2 meters. For those systems, the top section is cut at a specific length.*

Example : if you order an LS165 **12M40**, according to the chart below you will receive **five 2-meter sections, one half-length section, the telescopic section and 4 connectors.**

Chart No.3

Forestay max. length	No. of 2m sections	No. of 1m sections	No. of connectors	Telescopic section
7M30	3	0	2	1
8M40	3	1	3	1
10M40	4	1	4	1
12M40	5	1	5	1
14M50	6	1	6	1
16M50	7	1	7	1
18M50	8	1	8	1
20M50	9	1	9	1
22M50	10	1	10	1

2.3 DETERMINING WHICH SECTION LENGTH SHOULD BE USED

The example given is of a LS165 12M40, standard (i.e. not delivered to a shipyard), for a forestay measuring between 10.4 and 12.4 metres. According to the table above, you will receive: 5 two-metre external sections and 1 one-metre external section.

EXAMPLE No1 : your forestay measures between **10.40 and 11.40 metres (fig. A)**, you do not need the 1-metre section.

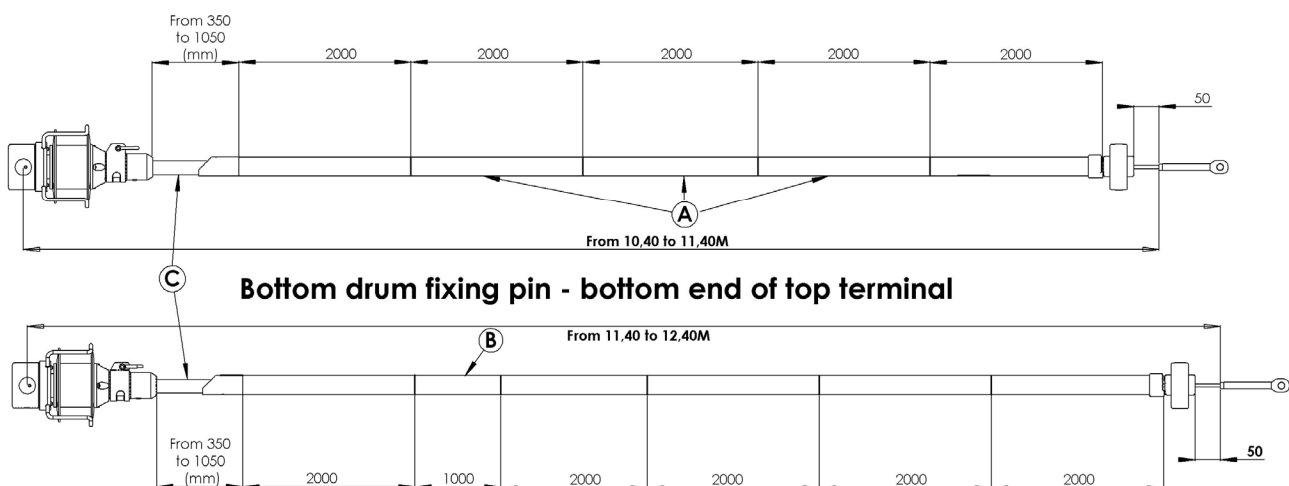

EXAMPLE No2: your forestay measures between **11.40 and 12.40 metres**, you do need the 1-metre section (**fig. B**); the latter fits above the last section.

In both examples, the exact length will be reached with the telescopic section (fig. C).

3- PRE-INSTALLATION NOTES

3.1 GENERAL REMARKS WITH REGARD TO FACNOR FURLING SYSTEM:

■ **Simple to assemble: no mast unstepping, no section cutting, no drilling**

The FACNOR headsail furling system is one of the easiest to install:

- it does **not require unstepping the mast**
- under most circumstances you **will not need to cut any section on account of the patented Facnor telescopic section.**
- **no drilling** is necessary.

■ **Maintenance free**

No particular maintenance is required because the drum and the halyard swivel are fitted with stainless steel bearings and polymer bushes filled and **waterproofed** with grease.

We recommend you clean the furling system with fresh water several times each the season to remove the salt deposits.

3.2 ELECTRICAL DANGER AND MAST SUPPORT



DO NOT BRING YOUR FURLING SYSTEM IN CONTACT WITH ELECTRIC CABLES OR HIGH TENSION LINES. The headsail reefing system is made from aluminium sections which are highly conductive. Contact by the system with power lines can be fatal.



DO NOT INSTALL YOUR REEFING SYSTEM WHEN STORMY WEATHER HAS BEEN FORECAST. A lightning striking the mast can travel down the system. Death could result from shocks induced from touching the reefing system.



MAKE SURE THE MAST IS SECURED BEFORE REMOVING THE BOTTOM FIXING PIN OF THE FORESTAY. Facnor reefing system can be assembled with the forestay in place. Kit components will be fed over the bottom of the forestay. Therefore, the bottom fixing pin will have to be removed. Before operating, support the front mast with a Spinnaker or Genoa halyard. **DO NOT USE A SNAP SHACKLE OR SHACKLE HALYARD BUT LASH IT.**



We recommend that you change your forestay if it is too old. You may contact one of our dealers. For information about the nearest Facnor retailer, contact us at +33 (0)2 33 88 50 22 or visit our web site : www.facnor.com .

The services of a professional yacht rigger or sailmaker could end up saving you time and should you improperly install the furler or encounter an unusual rigging problem.

3.3- PREPARING FOR ASSEMBLY:

■ Protecting the components

During assembly, we recommend you protect both the sections and the other items of the furling system, as rough ground may damage them.

■ Tools needed for assembly :

- a manual or electric screwdriver
- a hammer
- an adjustable spanner for the lower drum fitting pin

Different allen keys are supplied with the kit, as well as the Pozi drive/No2 bit for the section screws.

■ Preparing foil sections

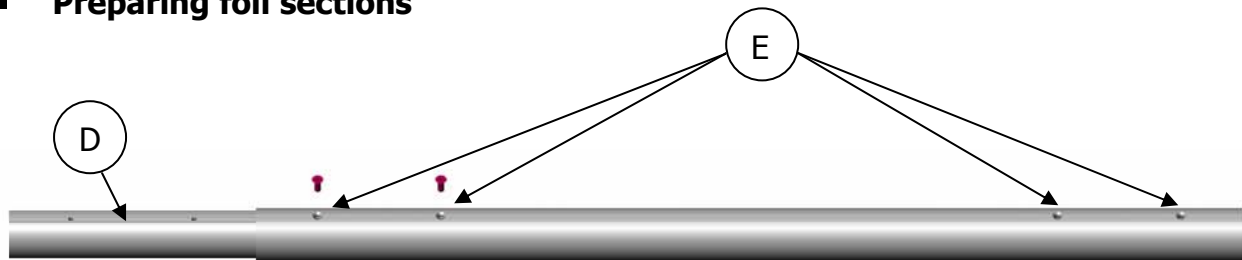

We recommend you prepare the sections before assembly. This involves fixing a connector (fig. D) to all of the twin-groove sections apart from one. The latter will be the top section. All of the external sections, **including the top section***, have symmetrical holes at each end (fig. E).

BEWARE: DO NOT TIGHTEN SCREWS AT THIS STAGE.

 * For furling systems installed for the first time, delivered to the shipyard, the top section may be shorter than 2 metres. For these reefing systems, the top section is cut to length. Therefore, there is no hole on the upper end of the top section, on which the top cap will be fixed.

4- ASSEMBLY STAGES :

4.1 – ASSEMBLY OF THE HALYARD DEFLECTOR*

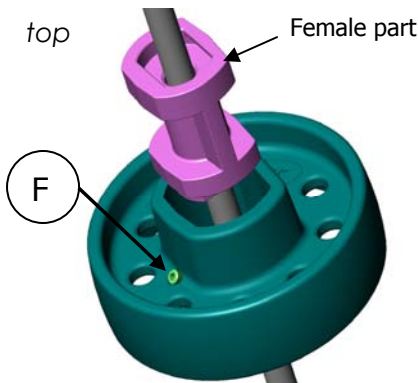

Slip the disk around the forestay, screw pointing up. Assemble the two half bearings **above** the deflector disk and around the forestay, the “female” part pointing up. Fit the bearing into the halyard deflector. Then tighten the screw (fig. F), which will fix the bearing in place.

***NOTE :** for LS/LX330 models, the halyard deflector wheel has been replaced by a block diverting the halyard and this is to be riveted onto the mast (see page p29 for further explanations).

4.2- ASSEMBLY OF THE TOP CAP AND THE TOP SECTION

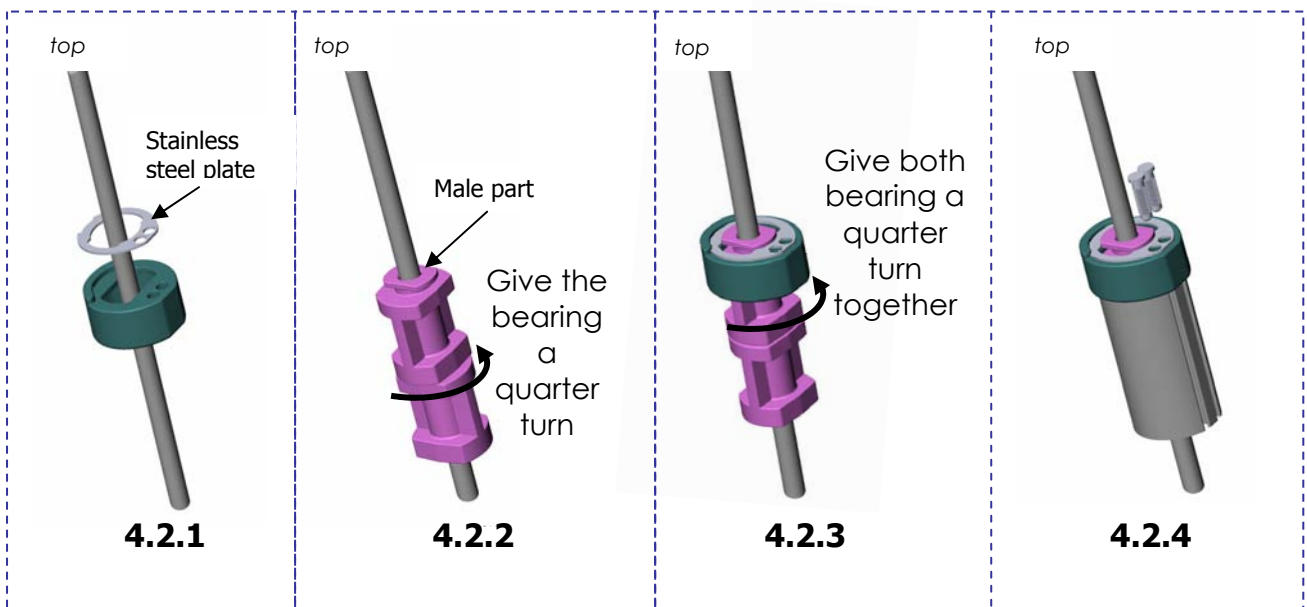

4.2.1- Slip the stainless steel plate and then the top cap around the forestay. Block the plate by slipping it into the notches on the cap, designed for this purpose.

4.2.2- Around the forestay, assemble a 1st bearing, then a 2nd, the “male” part pointing up. Fit the bearings together, and give the bottom bearing a quarter turn.

⚠ IMPORTANT : These two bearings are now joined.

4.2.3- Put the bearing set into the cap, then give another quarter turn to the bearings.

⚠ IMPORTANT : Doing this ensures that the bearings are fixed in place in the top cap.

4.2.4- Take the top section and fix it snugly into the top cap. If assembly is not possible, give the bearings a half turn in the cap.

Place the 2 pins into the holes in the top cap and the stainless steel plate. Then, tap them into the section grooves with a mallet.



The pins are simply used to fix the cap. Therefore, do not hit too hard or you may damage the cap.

4.3- FITTING THE HALYARD SWIVEL

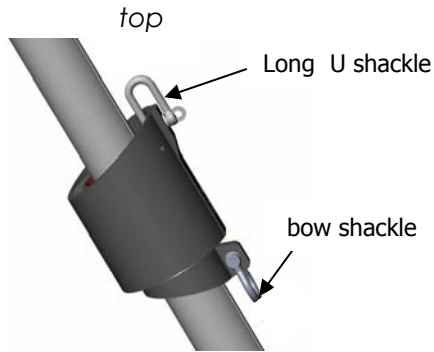

Ensure you fit the halyard swivel the right way up. Fix the two shackles. In order to raise the sections as high as possible, we recommend that you fit the halyard swivel and raise everything by way of a halyard.

⚠ IMPORTANT : Be sure to attach a down haul line to the halyard swivel so as to be able to recover it later.

4.4- ASSEMBLING FOIL SECTIONS

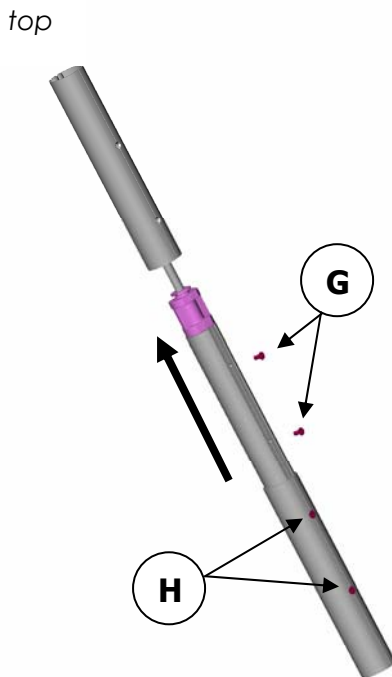

The top section is in place. Assemble a bearing around the forestay. Slip the next section, already assembled (see preparing the sections p.4), with the connector pointing towards the top of the forestay. With the help of the connector, push the bearing all the way up into the top section until the connector holes coincide with those of the top section.

Fit both screws (fig. G). then, slowly and firmly tighten the 4 screws (fig. G+H).

Repeat the operation until you reach the last section. DO NOT FIX ANYTHING TO THE LAST SECTION.



If your forestay requires the use of a 1-meter section, fit it above the lowest 2-meter section.

4.5- FITTING THE TELESCOPIC SECTION

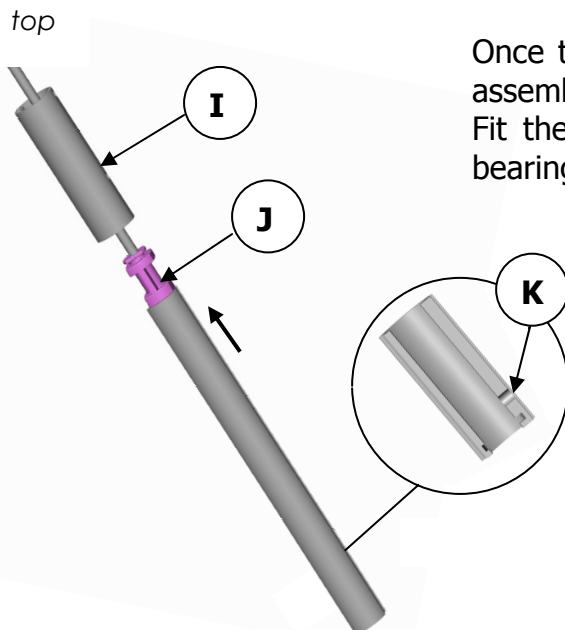

Once the sections have been hoisted as high as possible, assemble a bearing around the forestay.

Fit the telescopic section and push it up. That way, the bearing (fig. J) goes into the lowest foil section (Rep. I).



BEWARE : FIT THE TELESCOPIC SECTION TO THE FORESTAY AS INDICATED (fig. K). THE SIDE WITH ONLY ONE HOLE MUST BE POINTING DOWN.

4.6- FITTING THE FEEDER

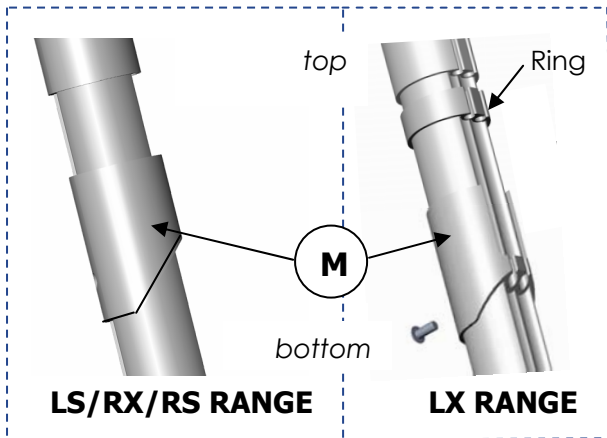

First fit the sail feeder (fig. M) to the telescopic section as indicated.

For LX models, before slipping the feeder, slip the ring. It is not necessary to fix the stainless steel part at this stage (see 4.11).

Fix the feeder to the telescopic section with the screw provided, tighten until fixed (see 4.11).

4.7- FITTING THE BEARING INTO THE TELESCOPIC SECTION

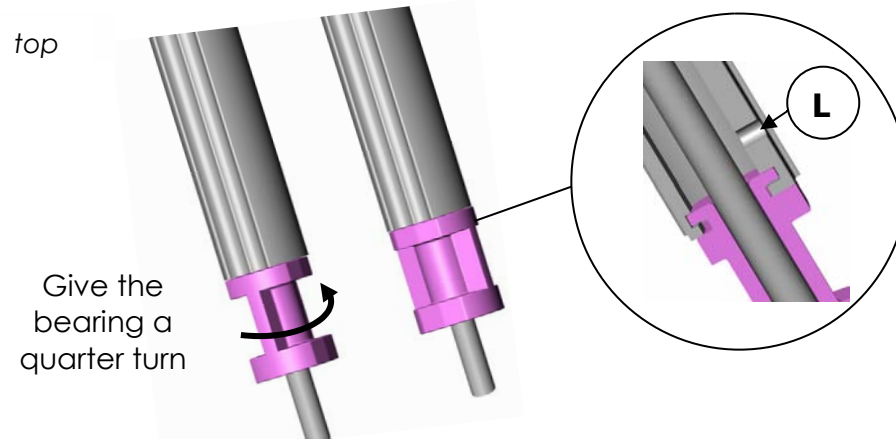

Assemble one bearing beneath the telescopic section, the male side pointing up. Fit the bearing to the telescopic section and give it a quarter turn.

⚠ IMPORTANT: Doing this ensures that the bearing is fixed in place at the bottom of the telescopic section (fig. L).

4.8- FIXING THE TELESCOPIC SECTION IN THE DRUM

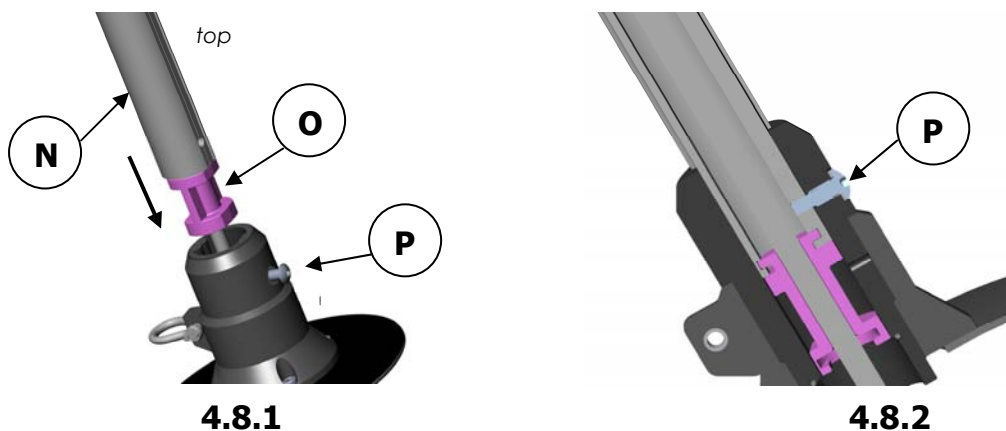

4.8.1- Slip the drum around the forestay. Loosen the screw (fig. P) slightly but sufficiently so that the telescopic section can slide inside the nose of the drum. Lower the telescopic section (fig. N), with its bearing (fig. O), until the bearing fits in snugly.

4.8.2- Tighten the locking screw (fig. P), which will join the drum to the telescopic section.

4.9- FIXING THE BOTTOM OF THE DRUM

There are two kinds of assembly for the lower fitting of the drum:

4.9.1- STANDARD ASSEMBLY: FORESTAY BOTTOM TERMINAL / EYE+LINK PLATES

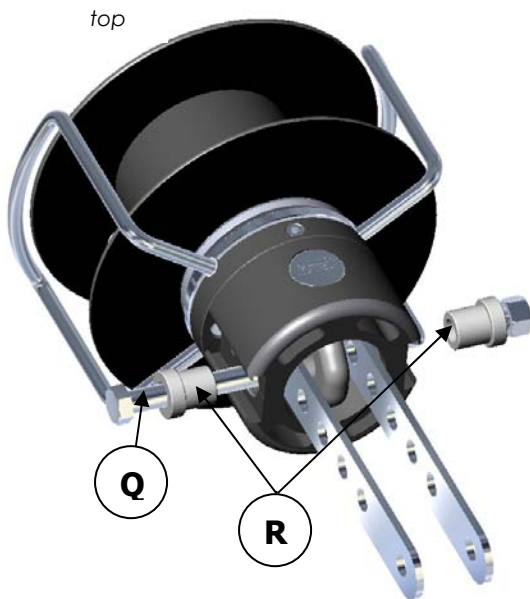

Fit the two drilled plates to the lower part of the drum.

Bolt together with the pin (fig. Q), after inserting the nylon bushes (fig. R).

 **IF THE PLATES ARE TOO LONG, CUT THEM AS SHOWN IN THE DIAGRAM.**

If possible, keep a hole available above the one you intend to use in case of further adjustment.



4.9.2- ASSEMBLY WITH TURNBUCKLE KIT : BOTTOM FORESTAY TERMINAL / TURNBUCKLE+ ARTICULATED JAW OR EYE + JAW

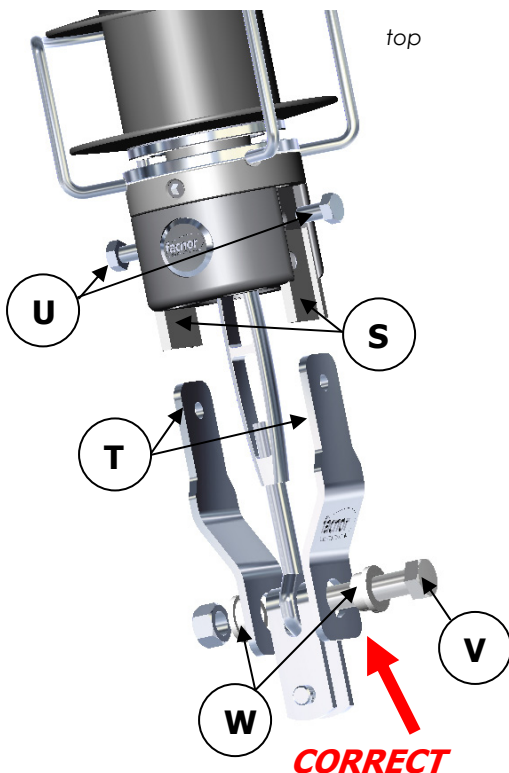

Slip the two flexible plastic strips (fig. S) into the slots situated on either side of the drum's base.

Fix the top of the stainless steel link plates (fig. T), found in the «Facnor turnbuckle kit», to the drum with the screws provided (fig. U). Lightly grease both threads before fixing.

Then, fix the bottom of the plates to the turnbuckle with the pin (fig. V), being careful to correctly position the nylon bushes (fig. W).

 **BEWARE: THE FITTING PIN (FIG. V) MUST ALWAYS BE FIXED TO THE UPPER SECTION OF THE JAW.**

 **NEVER FIX THE BOTTOM OF THE PLATES IN THE LOWER SECTION OF THE JAW**

WITH SUCH AN INSTALLATION THE FORESTAY IS NOT CORRECTLY ARTICULATED.

INCORRECT



IMPORTANT : In order to reach the optimum articulation of the forestay fitted with a furling system, it is absolutely necessary to have a toggle at the top end of the forestay. Furthermore, concerning the bottom terminal, it is recommended to have also a toggle.

4.10- ADJUSTING SECTIONS

Tighten the backstay to put some tension onto the forestay.
Leave the feeder piece resting on the drum.

Raise all of the sections together until they touch the top terminal of the forestay. Insert a screw into one of the lower holes of the last section.

⚠ BEWARE: DO NOT OVERTIGHTEN IT. Press the screw with your thumb and let the sections slowly descend until a hole coincides with the first of the threads on the telescopic section.

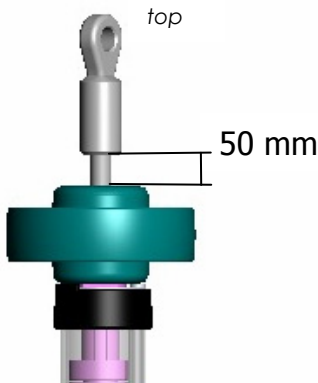

⚠ IMPORTANT :

- Make sure that sections have descended at least 50mm before the screw slots into place. Otherwise, proceed to the next hole, 100mm below.
- Leave a margin of at least 50 mm between the halyard deflector and the bottom of the forestay top terminal.
- The ideal position of the feeder is between 600 and 800 mm above the drum shackle.

4.11- FIXING THE SAIL FEEDER

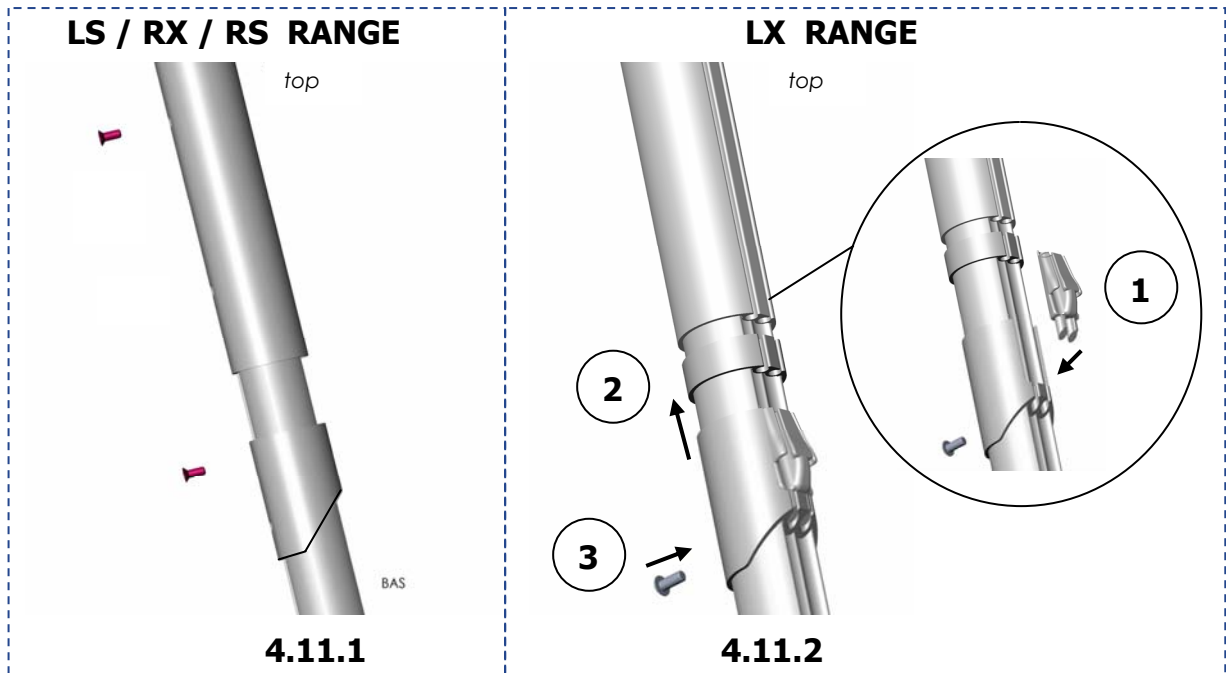

4.11.1- For the «LS», «RX» and «RS» range, aligns holes in the telescopic section with holes in the feeder. Then, screw down the feeder with the screw provided.

4.11.2- For the «LX» range, first, put the stainless steel feeder into its support. Then, align holes of the telescopic section and the feeder. Finally, screw down the feeder with screw provided.

5- INSTALLATION OF THE REEFING LINE

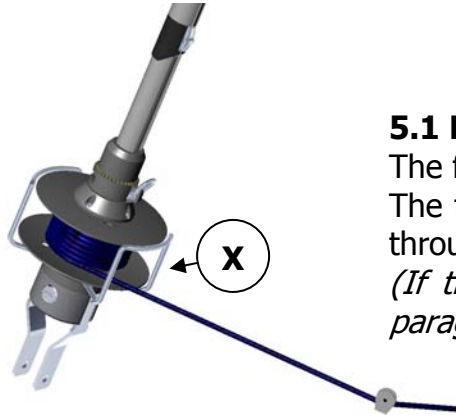

5.1 Positioning the front deck block

The furling line should be installed as shown. The furling line should run off at 90° to the forestay and through the stainless steel guide (fig. X).
(If the line does not run within the guide, please see paragraph 6.1 below)

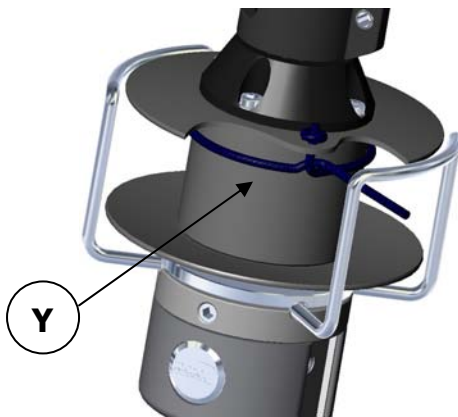

5.2 Setting the reefing line up

⚠ IMPORTANT: First half hitch the furling line (fig. Y) around the body of the drum. Then, feed the line through the hole in the top plate and tie a figure eight knot as shown.

🔴 *FURL A FEW EXTRA TURNS AROUND THE DRUM. WHEN THE SAIL IS FURLED UP, THERE SHOULD BE ALWAYS A FEW TURNS REMAINING AROUND THE DRUM.*

6- ADJUSTING THE FURLING LINE GUIDE



6.1 Slightly loosen the screw (fig. Z) so that the guide can rotate.

⚠ BEWARE: DO NOT REMOVE THE SCREW.

6.2 Orientate the guide by pulling the furling line up.

7- FITTING THE PRE-FEEDER (LX/RX RANGES)

For the LX/RX ranges, we supply one pre-feeder that helps to guide the sail while hoisting.

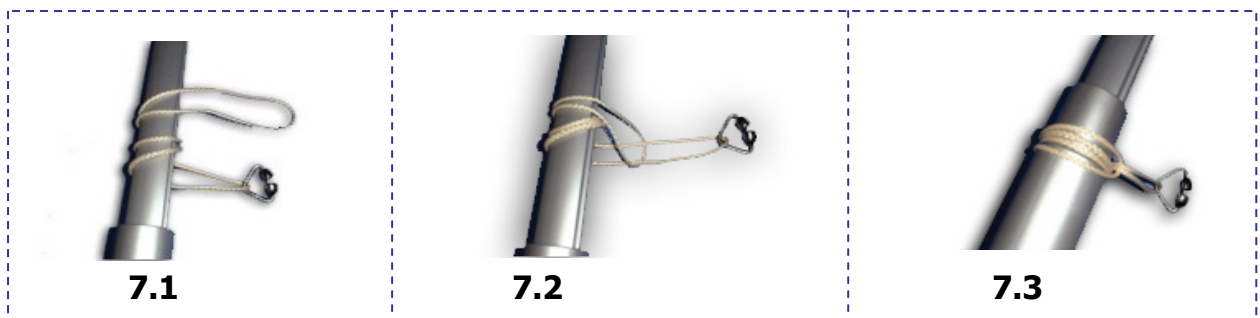

7.1- Wind the « vectran » loop twice round the telescopic section.

7.2- Pass the pre-feeder through the loop as shown.

7.3- Position the pre-feeder at the suitable height and pull tight. Once the sail is fitted, loosen the loop and remove the pre-feeder. Store for future use.

8- SPECIFIC INSTALLATIONS

Installation without deflector wheel or when using a sail with shorter luff:

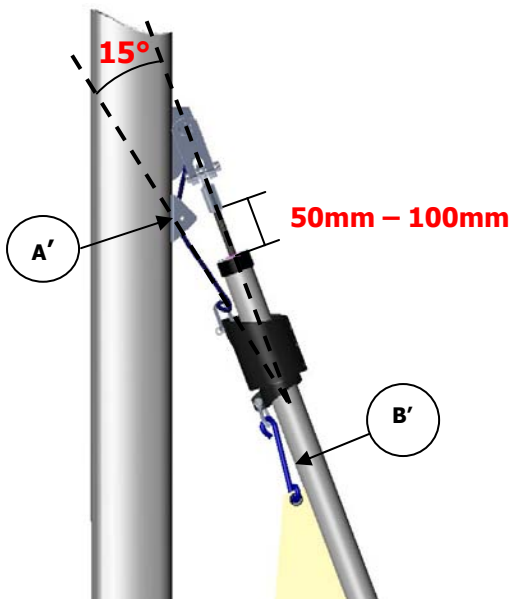

- Without deflector wheel (installation for the LS/LX330):

If the halyard swivel is not used, fix a block on the mast (fig. A'); so that the halyard runs off at 15° to the forestay. Also insure that the top cap is positioned around 50mm from the bottom end of the top forestay.

- Sail with shorter luff (i.e. Storm Sails and Working Jibs): The halyard swivel virtually eliminates halyard wrap ; however, when using a shorter sail, rig a short strop (fig. B') between the head of your sail to allow the top of the halyard swivel to be positioned around 50mm from the top section cap, when your sail is fully hoisted.

9- CHANGING FURLING SYSTEM INTO HEADFOIL (LX/RX/RS REMOVABLE DRUMS)

Changing your LX/RX or RS furling system into headfoil allows lowering the tack point and therefore gaining length in the luff. You can then use a sail with a longer luff than your cruising genoa. This easy operation can be sequenced in 3 steps :

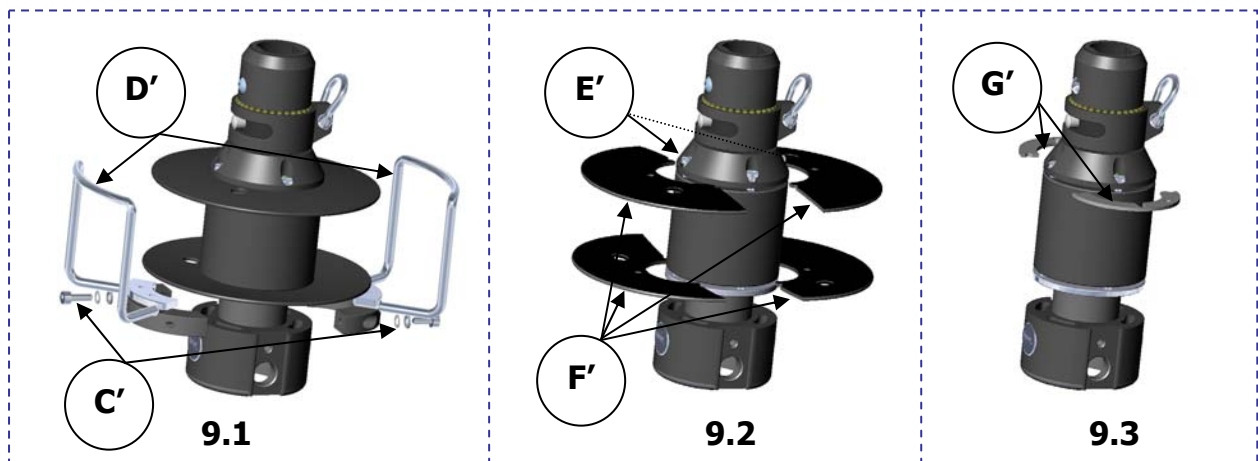

9.1- Dismantling the furling line guides :

Remove the guides (fig. D') after removing the two screws (fig. C').

9.2- Removing half plates :

Remove the two screws (fig. E') that go through the half plates. Slightly loosen the two other screws in order to release the four half plates (fig. F').

9.3- Installing the half protection rings :

Slip the two half protection rings (fig. G'), then tighten the four screws back (fig. E').

Follow the steps the other way round to come back to your original furling systems.

10- POST-INSTALLATION CHECK LIST

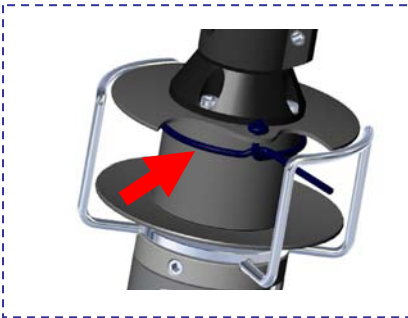

- The furling line has been half hitched round the drum

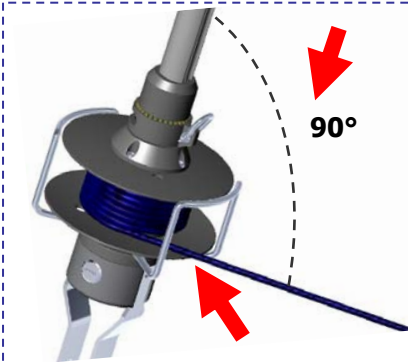

- The furling line runs at 90° to the foil sections
- The furling line runs through the stainless steel guide
(If not, see p28, "adjusting the furling line guide")

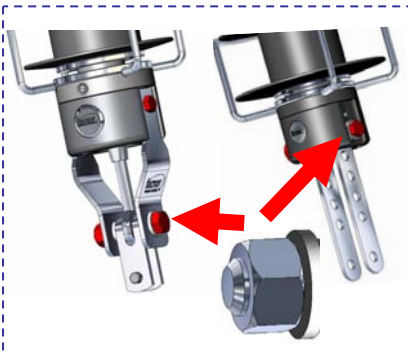

- The bottom pin of the forestay is correctly bolted, at least one thread is showed beyond the bolt
(If the furling system is fitted with link plates, check the upper fixing screws)

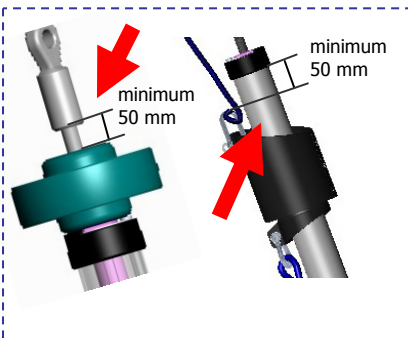

When the sail is hoisted and the halyard is tensioned correctly :





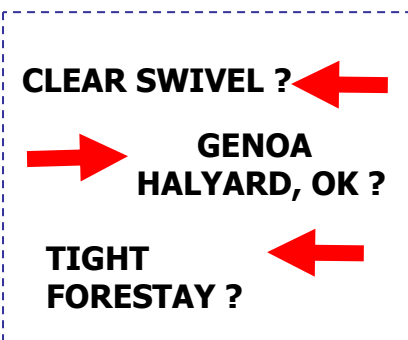

- distance between the halyard deflector & the bottom end of the top forestay terminal
=50mm minimum – 150 maximum
- distance between halyard swivel & top cap
=50mm minimum – 100 mm maximum*

* space to allow for change in luff length of Genoa



- The swivel is clear of any halyard
- The genoa halyard is correctly tensioned
- The forestay is sufficiently tight

11- FURLING TIPS

-  When unfurling, guide the reefing line so that it does not run out too fast. Keep the reefing line under control as you furl. Take care it does not override.
-  When you reef, check the Genoa car to ensure the correct tension on the leach and foot.
-  Check that other halyards are clear of the reefing system.
-  Cleat the furling line and secure jib sheets when you have the required sail area.
-  It is recommended that you have a spare sail on board. You can use an old Genoa with a luff tape to fit the Facnor groove.
-  Before leaving your boat, make sure that the sail is tightly furled and that the jib sheets are wrapped around the furled sail two or three times, and the reefing line is secured.
-  When reefing in light airs, maintain some tension on the jib sheets to ensure the sail is properly rolled up.

 **DO NOT FORCE** the reefing system. Check for reasons if the sail is difficult to furl.



Please do not hesitate to contact our experienced sales team or the FACNOR dealers whose list is available on our web site : www.facnor.com and discover the wide range of FACNOR products.

ENJOY YOUR SAILING !