

► TÊTE DE MÂT NON RÉTREINT - GRÉEMENT EN TÊTE / MASTHEAD NON TAPERED - MAST HEAD RIG

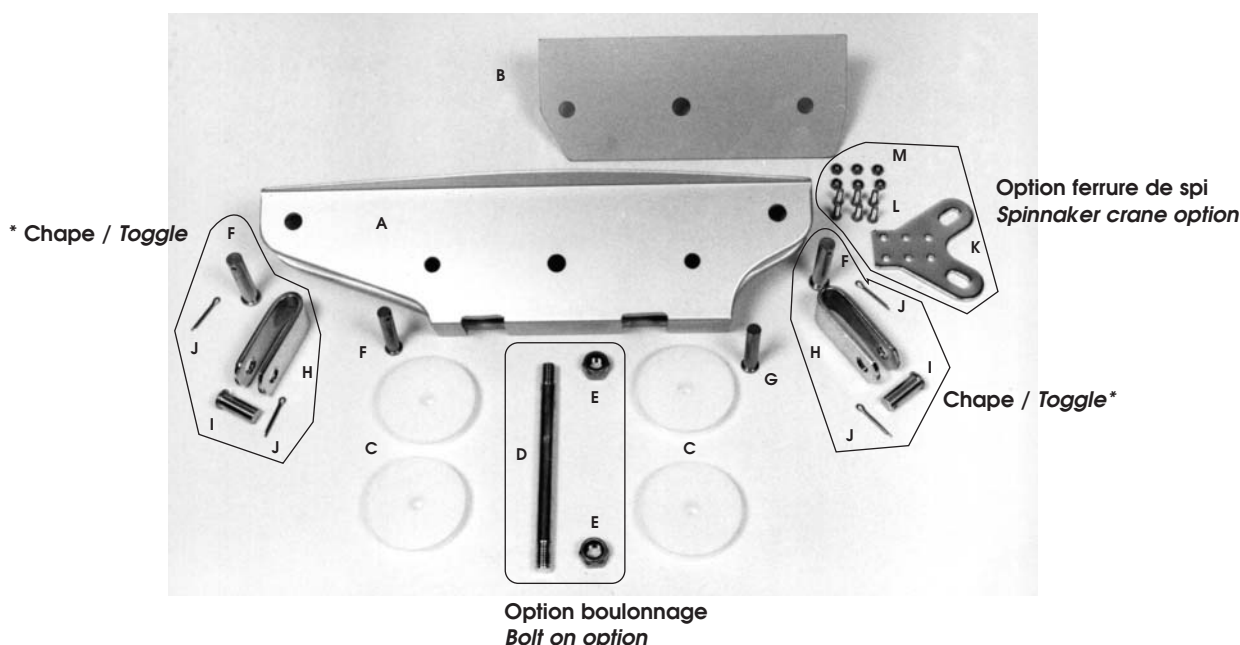
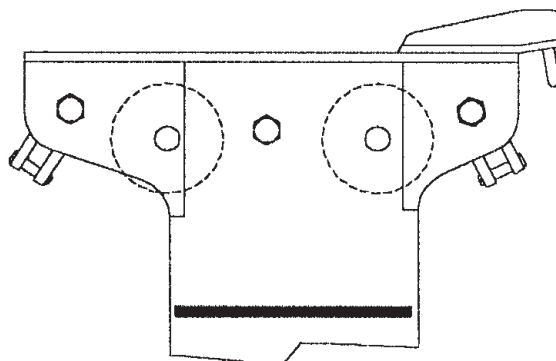

		F135		F195		F305		F305		F385/F460		F580		F740		F1060		F1395		F2390		F3360				
RÉFÉRENCES	SECTION n°	BODY n°	4	3	3	3	3	3	3	3	3	3	3	6	6	6	5	5								
	LONGUEUR mm	LENGTH mm	276	375	403	417	409	442	460	587	608	620	730													
	CODE COMPLET	COMPLETE CODE	30004027615	30003023755	30003024035	30003024175	30003024305	30003024425	30003024605	30006015875	30006016085	30005026205	30005027305													
	DESIGNATION	DESCRIPTION	CODE	QT	CODE	QT	CODE	QT	CODE	QT	CODE	QT	CODE	QT	CODE	QT	CODE	QT	CODE	QT	CODE	QT	CODE	QT		
A	CORPS	BODY	30004132715	1	30003023752	1	30003024032	1	30003024172	1	30003024302	1	30003024422	1	30003024602	1	30006015872	1	30006016082	1	30005026202	1	30005027302	1		
B	CLOISON	CHEEK	30004032712	1	30003113755	1	30003114035	1	30003114175	1	30003114305	1	30003114425	1	30003114605	1										
C	REAS	SHEAVES	48510481215	4	48510801525	4	48510801525	4	48510801525	4	48510801525	4	48530851515	4	48510801525	4	48511102125	4	48511102125	4	48511102125	4	48511402125	4		
	GOUPILLE		28803032200	1	28803032200	1	28803032200	1	28803032200	1	28803032200	1	28803032200	1	28803032200	1	28803040400	2	28803040400	2	28803032200	1	28803032200	1		
	CACHE AXE		41201501044	1	41201501044	1	41201501044	1	41201501044	1	41201501044	1	41201501044	1	41201501044	1					41201501044	1	41201501044	1		
	RONDELLES	WASHERS													28601010000	2	28601018000	2	28601018000	2	28601018000	2	28601020000	2		
F	AXE DE TÊTE	PIN	40020110056	1	40020212052	1	40020212052	1	40020212052	1	40020212052	1	40020212052	1	40020110056	1	40020218095	2	40020218095	2	40020212052	1	40020212052	1		
G	AXE DE TÊTE	PIN	40020210040	1	40020112065	1	40020112065	1	40020112065	1	40020112065	1	40020112065	1	40020210040	1	40020218078	2	40020218078	2	40020112065	1	40020112065	1		
OPTION BOULONNAGE																										
D	AXE TRAVERSANT	PIN STRAIGHT	40020510110	1	40020512135	1	40020512135	1	40020512150	1	40020512160	1	40020512160	1	40020512170	1										
E	ECROU INDES.	NYLOC NUTS	28600510000	2	28600512000	2	28600512000	2	28600512000	2	28600512000	2	28600512000	2	28600512000	2										
	RONDELLES	WASHERS	28601010000	2	28601012000	2	28601012000	2	28601012000	2	28601012000	2	28601012000	2	28601012000	2										
OPTION FERRURE DE SPI																										
K	FERRURE DE SPI	SPI CRANE	30015100944	1	30016120944	1	30016120944	1	30016120944	1	30016120944	1	30016120944	1	30016241504	1	30016241504	1	30017141324	1	30017141324	1	30017141324	1	30017141324	1
L	VIS	SCREWS	28600706016	6	28600706016	6	28600706016	6	28600706016	6	28600706016	6	28600706016	6	28600706016	6	28600706016	6	28600706020	8	28600706020	8	28600706020	8	28600706020	8
M	ECROU INDES.	NYLOC NUTS	28600506000	6	28600506000	6	28600506000	6	28600506000	6	28600506000	6	28600506000	6	28600506000	6	28600510000	6	28600510000	8	28600512000	8	28600512000	8	28600512000	8

* Réf. chape : voir page 5 / Toggle : see page 5.