

► TÊTE DE MÂT RÉTREINT / MASTHEAD TAPERED

2004

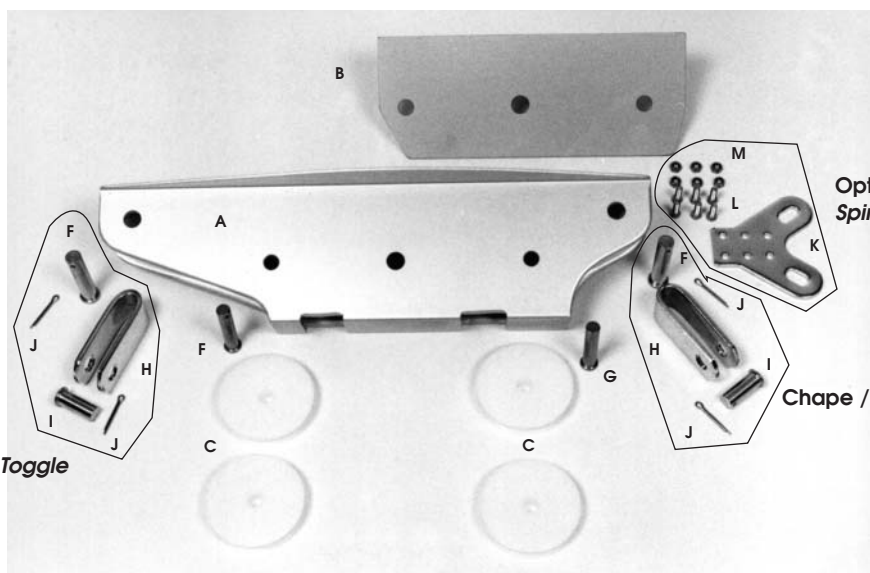
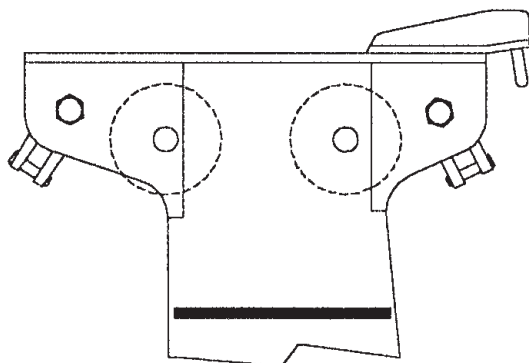

Option ferrure de spi
Spinnaker crane option

Chape / Toggle*

* Chape / Toggle

Tableau des rétreints standards / Taper chart

		F135	F195	F305	F385	F460	F580	F740	F1060	F1395	F2390	F3360
LONGUEUR	GRÉEMENT EN TÊTE MAST HEAD RIG	1500	1500	1750	1750	1750	2000	2000	2250	2250	2250	3000
	GRÉEMENT 7/8 7/8 RIG	1750	1750	2000	2250	2250	2500	2500	2750	2750		

		F135		F195		F305		F385		F460		F580		F740		F1060		F1395		F2390		F3360				
RÉFÉRENTS	SECTION n°	BODY n°		3		3		3		3		3		3		6		6		5		5				
	LONGUEUR mm	LENGTH mm		345		325		377		390		442		415		537		558		705		740				
	CODE COMPLET	COMPLETE CODE		30004024615		30003023465		30003023535		30003023775		30003023905		30003024425		30003024155		30006015375		30006015585		30005017055		30005017405		
	DESIGNATION	DESCRIPTION	CODE	QT	CODE	QT	CODE	QT	CODE	QT	CODE	QT	CODE	QT	CODE	QT	CODE	QT	CODE	QT	CODE	QT	CODE	QT		
A	CORPS	BODY	30004032462	1	30003023462	1	30003023532	1	30003023772	1	30003023902	1	30003024422	1	30003024152	1	30006015372	1	30006015582	1	30005017052	1	30005017402	1		
B	CLOISON	CHEEK	30004132465	1	30003113465	1	30003113525	1	30003113775	1	30003113915	1	30003114425	1	30003114155	1										
C	REAS	SHEAVES	48510481215	4	48510801525	4	48510801525	4	48510801525	4	48510801525	4	48530851515	4	48510801525	4	48511102125	4	48511102125	4	48511102125	4	48511402125	4		
	GOUPILE		28803032200	1	28803032200	1	28803032200	1	28803032200	1	28803032200	1	28803032200	1	28803040400	2	28803040400	2	28803040400	2	28803032200	1	28803032200	1		
	CACHE AXE		41201501044	1	41201501044	1	41201501044	1	41201501044	1	41201501044	1	41201501044	1	41201501044	1					41201501044	1	41201501044	1		
	RONDELLES	WASHERS											28601010000	2	28601018000	2	28601018000	2	28601018000	2	28601018000	2	28601020000	2		
F	AXE DE TÊTE	PIN	40020110056	1	40020212052	1	40020212052	1	40020212052	1	40020212052	1	40020212052	1	40020110056	1	40020218095	2	40020218095	2	40020212052	1	40020212052	1		
G	AXE DE TÊTE	PIN	40020210040	1	40020112065	1	40020112065	1	40020112065	1	40020112065	1	40020112065	1	40020210040	1	40020218078	2	40020218078	2	40020112065	1	40020112065	1		
OPTION FERRURE DE SPI																										
K	FERRURE DE SPI	SPI CRANE	30015100944	1	30016120944	1	30016120944	1	30016120944	1	30016120944	1	30016120944	1	30016241504	1	30017141324	1	30017141324	1	30017141324	1	30017141324	1	30017141324	1
L	VIS	SCREWS	28600706016	6	28600706016	6	28600706016	6	28600706016	6	28600706016	6	28600706016	6	28600706016	6	28600706020	8	28600706020	8	28600706020	8	28600706020	8		
M	ECROU INDES.	NYLOC NUTS	28600506000	6	28600506000	6	28600506000	6	28600506000	6	28600506000	6	28600506000	6	28600506000	6	28600510000	8	28600510000	8	28600512000	8	28600512000	8		

* Réf. chape : voir page 5 / Toggle : see page 5.